

# BOARDROOM, GALLERY, CONTROL TABLES





## THE CHALLENGE

A health care organization needs a nearly 50-foot elliptical boardroom table as well as gallery and control tables of a unique design and with carefully integrated technology. It wants detailed drawings of the table in its boardroom and a mock-up of a section of the table to ensure it will meet every need of the important team that will meet around this showpiece.

## THE SOLUTION

WallGoldfinger has been designing, engineering and creating the highest quality corporate furniture for decades. It is known for its custom work, particularly when it comes to expansive boardroom tables as well as elliptical tables. WallGoldfinger is also a leader in technology integration and has the concept illustration, design engineering and woodworking team to build exactly what this organization seeks, including a detailed mock-up the client can try on for size.

## DESIGNER

Tilton, Kelly + Bell, LLC, Chicago, IL

## MATERIALS

Quartered ash veneer in a radial pattern, solid ash, Slate Gray plastic laminate

## TECHNOLOGY

LED monitors, gooseneck microphones, power boxes

## UNIQUE ATTRIBUTES

Large size, curved design, angled monitors for maximum comfort when viewing

concept illustrations

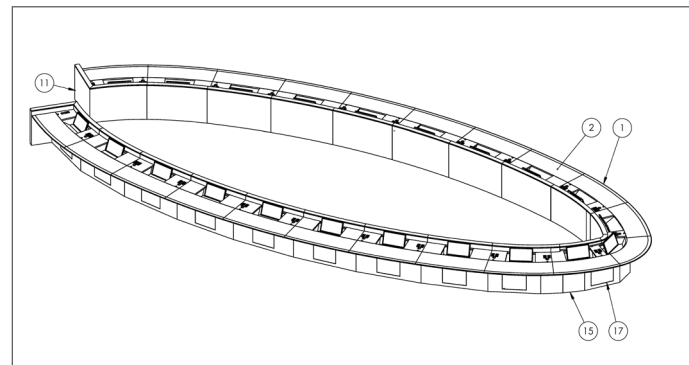
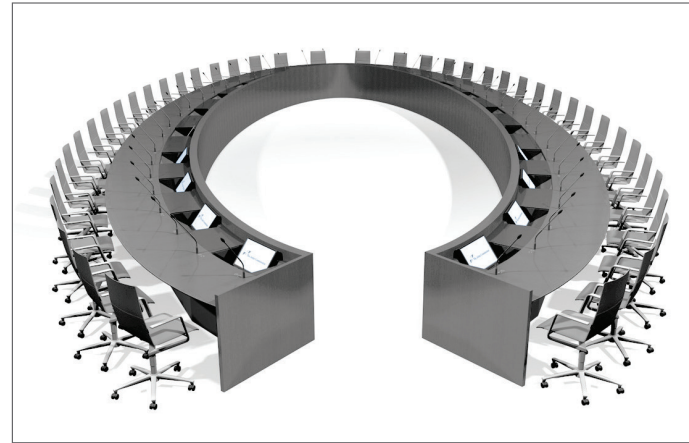

floor plan

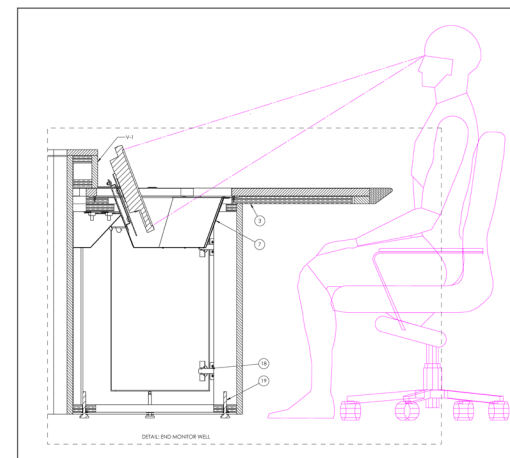
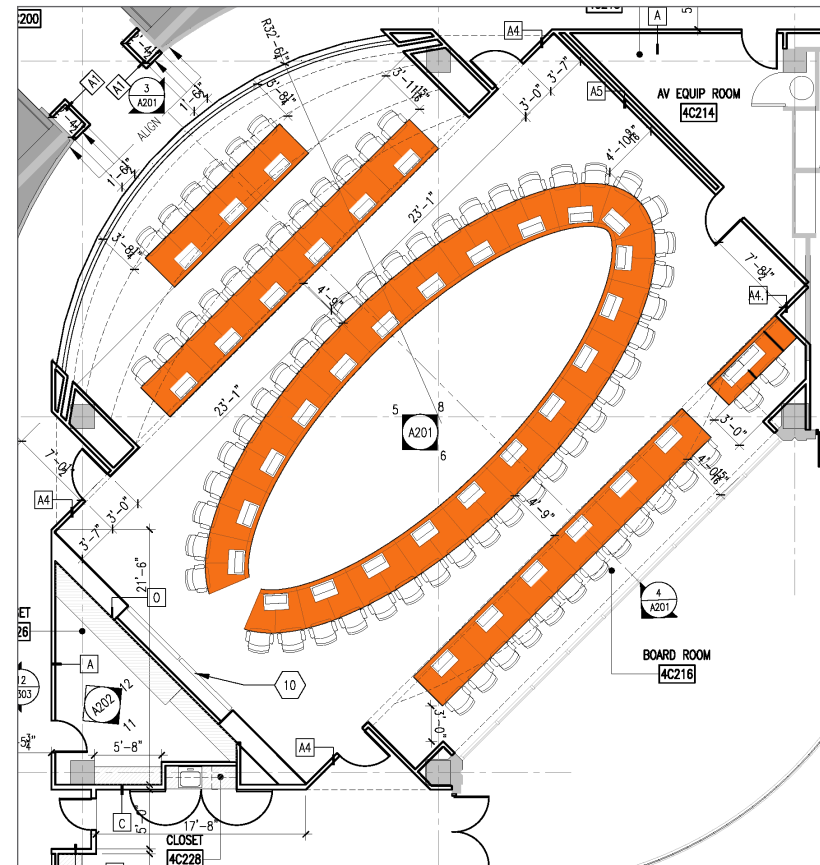

engineered drawing



in progress



---

*"I am in love. I don't want anyone to even use the room."*

— Client response to furniture installation

---



JOI-524